

PRODUCT DATASHEET

Panasonic

Product Name :	Two Gang One Way Switch
Product Code :	WKTC00092**/WKTT00092**
Product Series :	Karre Plus
Technical Specifications:	
<i>Rated Current :</i>	10AX, 250V ~
<i>Terminal Type :</i>	Screw Terminal
Material :	ABS (Acrylonitrile Butadine-Styrene)
Colour Options** :	WH: White, BG: Beige, BR: Bronze, DR: Dark Grey, SL: Silver
Certificates :	VDE, EAC, CE, WEEE
Cable Standard:	
<i>Cable Diameter :</i>	1mm ² -2,5mm ²
<i>Applicable Cable:</i>	Solid Wire, Stranded Wire

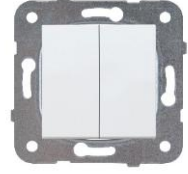

Screw Terminal

Wiring Diagram:

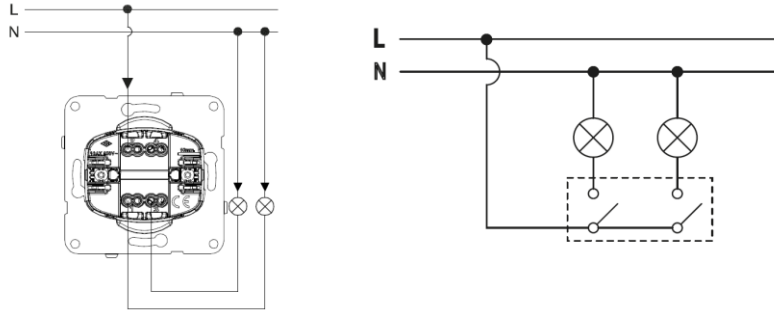

Dimensions:

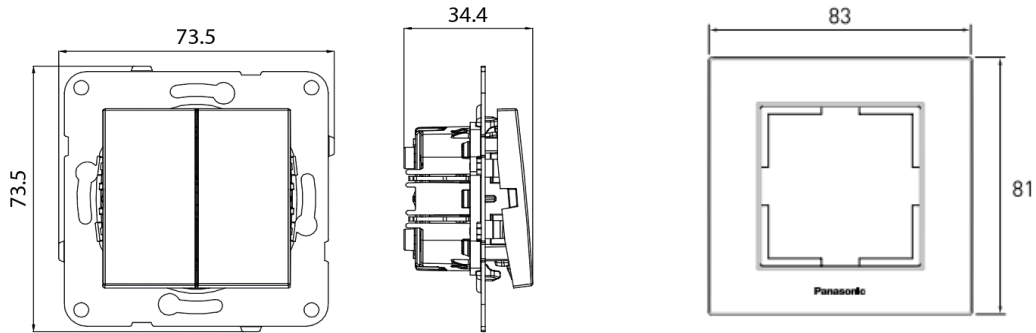

Panasonic Electric Works Elektrik.San. ve Tic. A.Ş.
 Abdurrahmangazi Mah. Ebubekir Cad. No: 44 Sancaktepe / İstanbul Tel: 0216 564 55 55 Fax: 0216 564 55 44
 ewtr.panasonic.com