

PRODUCT DATASHEET

V:KO
by **Panasonic**

Product Name : Carmen Illuminated One Way Switch

Product Code : 90566019

Product Series : Carmen

Technical Specifications:

Rated Current : 10AX, 250V~

Terminal Type : Quick Connection

Material : ABS (Acrylonitrile Butadine-Styrene)

Certificates : TSE, VDE, NF, EAC, CE, WEEE

Cable Standard :

Cable Diameter : 1mm²-2,5mm²

Applicable Cable: Solid Wire, Stranded Wire



Screwless
Terminal

Wiring Diagram:

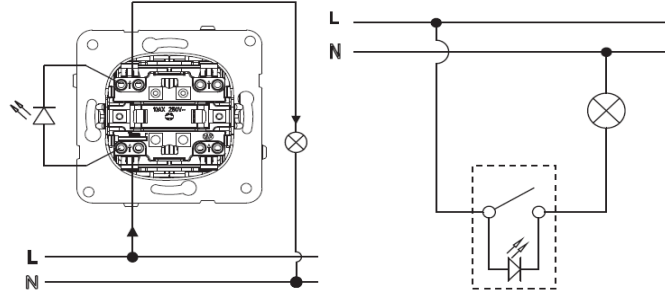

Dimensions:

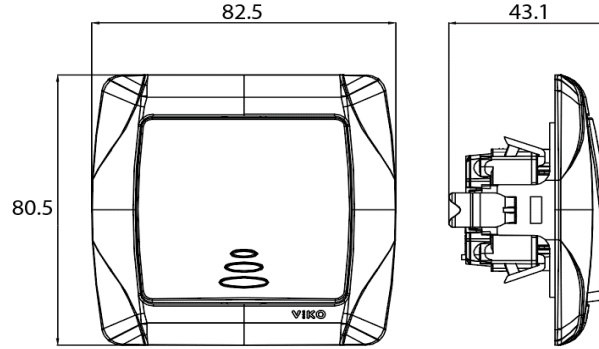

Panasonic Electric Works Elektrik.San. ve Tic. A.Ş.
Abdurrahmangazi Mah. Ebubekir Cad. No: 44 Sancaktepe / İstanbul Tel: 0216 564 55 55 Fax: 0216 564 55 44
ewtr.panasonic.com